

# MICHIGAN ASSOCIATION OF WESTERN HORSE CLUBS, INC.

RULE BOOK and CONSTITUTION

2007 EDITION



Michigan Association of Western Horse Clubs was established in 1946 to encourage and promote the interests of individual clubs and members in better horsemanship, showmanship, and sportsmanship



## **SHINVILLE AWARD RECIPIENTS LIFETIME MEMBERSHIP**

With Gratitude to the following members  
Dedicated to the Principles Guiding  
The Michigan Association of Western Horse Clubs

Chet Geukes	1965
Earl J. Clark	1966
Clifton Schelas	1967
Arlyne Clark	1968
Jack Chaddock	1968
Kate Gaines	1970
Ted Whipple	1971
Ida Cauffman	1972
Joe Varley	1973
Jim Hamilton	1974
Ernie Clark	1975
Dick & Joan Corell	1976
Bob & Barb Best	1976
Carolyn Hamilton	1977
Robert Peart	1978
Doug & Thelma Graham	1979
Bob & Jean Tacy	1979
Carl Davis	1982
Ron Strefling	1983
Lester Guthrie Sr.	1984
Charles Moore	1985
Tom & Tami Gear	1993
Conrad L. Andrews	2000
Dan & Alice Bell	2004
Dave & Lori Romeo	2005

## 2007 Show Grounds and Contacts

**Derbyshire Equestrian Center**  
6868 Washington Avenue, Stevensville, MI 49127  
Lucinda Henderson (269) 429-7269

**Van Buren Saddle Club**  
Red Arrow Highway, Hartford, MI 49057  
Barb Buckham (269) 679-5544

**Lazy L Equestrian Center**  
31201 29<sup>th</sup> Street  
Paw Paw, MI 49079  
Donna Kirklakin (269) 628-0331

## 2007 MAWHC APPROVED HORSE SHOWS

<b>April 22<sup>nd</sup></b>	Fun Show @ Lazy L Equestrian Center (no points)
<b>May 5<sup>th</sup></b>	Fun Show @ Van Buren Saddle Club (no points)
<b>May 20<sup>th</sup></b>	Van Buren Saddle Club
<b>June 9<sup>th</sup></b>	Lazy L Equestrian Center
<b>June 11<sup>th</sup></b>	Van Buren Saddle Club
<b>June 23<sup>rd</sup></b>	Derbyshire Equestrian Center
<b>June 24<sup>th</sup></b>	Derbyshire Equestrian Center
<b>August 4<sup>th</sup></b>	Lazy L Equestrian Center
<b>September 15<sup>th</sup></b>	Board of Directors Show @ Van Buren Saddle Club ( <i>double point show</i> )
<b>September 16<sup>th</sup></b>	Van Buren Saddle Club

## 2007 Officers and Board of Directors

### Officers

President	Shelly Hartmann	(269) 639-9707
Vice President	Holli Rutter	(269) 325-6606
Secretary	Shelley Ziebarth	(269) 463-5339
Treasurer	Terri Tripp-Novotny	(269) 637-6242

### Directors

2 Year Term (2007-2008)	Tami Gear	(269) 208-3944
2 Year Term (2007-2008)	Pam LaPorte	(574) 339-1866
1 Year Term (2007 appointed)	Kendra Truhn	(269) 545-3575
1 Year Term (Past President)	Dave Romeo	(269) 539-0316

### Youth Directors

1 Year Term	Brittany Bly
1 Year Term	Kelsi Brinks

### Appointed Positions

Point/Membership Secretary	Tami Gear	(269) 208-3944 or tami@kimgear.com
Newsletter Editor	Kevin Novotny	(269) 637-6242 or kntnt@msn.com

### WEBSITE

Please visit our Club website at <http://www.mawhc.tripod.com>  
for showdates, club business, award listings and photos.

**TABLE OF CONTENTS  
CONSTITUTION**

Title, Affiliation.....	7
Mission Statement.....	7
Objects.....	7
Memberships.....	7
Delegates.....	8
Officers.....	8
The President.....	8
Vice President.....	8
The Secretary.....	8
The Treasurer.....	9
Directors.....	9
Committees.....	9
Meetings.....	9
Point Secretary.....	10
Disciplinary Action.....	10
Constitution Amendment.....	10
Voting Procedure for Officers and Directors.....	10

**TABLE OF CONTENTS**  
**RULES AND REGULATIONS**

Shinville Award Lifetime Membership.....	2
Show approvals.....	11
Location and Time.....	11
Show committee.....	12
Ringmaster.....	12
Show Steward.....	13
Show Secretary.....	13
Timer.....	13
Judge.....	13
Exhibitors and Family.....	14
Points and Awards.....	14
Certificate of Recognition.....	15
List of Optional Classes.....	16
List of Mandatory Classes.....	16
General Rules for Judged Events.....	17
Halter Division.....	18
Reg. Quarter Horse Halter .....	19
Reg. Appaloosa Horse Halter .....	19
Reg. Fine Horse Halter.....	19
Reg. Color Horse Halter.....	19
Reg. Paint Horse Halter .....	19
Non Registered Horse Halter.....	19
Open Showmanship at Halter.....	19
Western Horsemanship Division.....	20
Western Pleasure Division.....	21
Reg. Quarter Horse Saddle.....	22
Reg. Appaloosa Horse Saddle.....	22
Reg. Paint Horse Saddle.....	23
Reg. Fine Horse Saddle.....	23
Reg. Color Horse Saddle.....	23
Non. Registered Horse Saddle.....	23
English Equitation Hunt Seat.....	23
Saddle Seat - General Rules.....	24
Open Hunt and Saddle Seat General Rules.....	24
Hunt Seat, Saddle Seat.....	24
Lead Line Division .....	25
Pee Wee Division.....	25
Green Horse or Green Rider Division.....	26
Pony Division.....	26
Over 30 Class.....	27
Junior Horse/Pony Pleasure Class.....	28
Senior Horse/Pony Pleasure Class.....	28
Open Performance Class.....	28
Open Reining Class.....	28
Reining Pattern A.....	30
Reining Pattern B.....	31
Reining Pattern C.....	32
General Rules for contest Events.....	33
Age Groups for Contest Events.....	34
Clover Leaf Pattern.....	35
Down and Back.....	36
Open Trail Class .....	37
MAWHC Queen Contest.....	37
Year End Awards.....	38
Special Awards.....	39

## **CONSTITUTION**

### **ARTICLE I**

#### **Title, Affiliation and Purpose**

##### **SECTION I: Title**

This Association shall be known as the Michigan Association of Western Horse Clubs, Incorporated (MAWHC), and shall, at all times, be operated and conducted as a not for profit organization in accordance with the rules and regulations of the Internal Revenue Service and the State of Michigan.

##### **SECTION II: Affiliation**

This Association shall be affiliated with the appropriate breed associations and/or organizations, and shall conform to the rules and regulations within those associations and organizations.

##### **SECTION III: Mission Statement**

To encourage and promote the interests of individual members and individual clubs in better horsemanship, showmanship, and sportsmanship. To achieve this mission, the association seeks to:

1. Encourage humane care
2. Promote Member Organizations
3. Adhere to Breed Rules
4. Promote youth and Adult activities and events.

### **ARTICLE II OBJECTS**

##### **SECTION I: Objects**

The Objects of this association are as follows:

1. To encourage and promote the interests of individual members and individual clubs in better horsemanship, showmanship, and sportsmanship.
2. To effect a better understanding among those holding competitions and exhibitions.
3. To make and enforce uniform rules governing such competitions and exhibitions.
4. To adjust disputes which may arise between Horse Show Committees and Exhibitors or spectators at such exhibitions and as otherwise stated in its certificate of incorporation.

### **ARTICLE III MEMBERSHIP**

##### **SECTION I**

The membership is to consist of persons united by a common interest in horses. Individual Membership is permitted as well as Member Clubs. All members are eligible for Year End Awards.

##### **SECTION II**

Any person may make application for Associate Membership, acceptance of that shall entitle the senior applicant to privileges not available to non-members, including the following:

1. Eligible to serve as a Director, Committee Member, or Officer.
2. Eligible for Association awards subject to a payment of a tabulation fee.
3. Rule Book-Show Listings
4. Senior Associate Members eligible to elect or impeach Directors.
5. Associate Members may request to meet with the Board of Directors at a scheduled meeting.

##### **SECTION III**

Club and Associate Membership may be obtained by making proper application and remittance of dues to MAWHC Treasurer.

##### **SECTION IV**

The Directors may change club or individual membership dues when it is necessary for the survival, not the profit of MAWHC. Any changes must be published by October 10th of the previous year.

**ARTICLE IV  
DELEGATES**

**SECTION I**

Each paid Member Club shall be privileged to appoint one delegate, and this delegate has the right to vote for the Member club at any MAWHC meeting.

**ARTICLE V  
OFFICERS**

**SECTION I**

The officers of this Association shall be President, Vice President, Secretary, and Treasurer. The President, Vice President, Secretary and Treasurer shall be elected annually by the MAWHC general membership at the Annual Business Meeting of the Association, shall hold office during the ensuing year, and until the successors are duly elected.

**ARTICLE VI  
THE PRESIDENT**

**SECTION I**

The President shall preside at all meetings of the Association and of the Board of Directors and shall, with the Secretary, he/she shall sign all contracts and obligations of the Association and perform such other duties as may be assigned to him or her by the Board of Directors.

**SECTION II**

The President may at any time call a meeting of the Board of Directors and shall do so at the request of three Directors.

**SECTION III**

The President shall have authority to make modification in the application of the rules under special or emergency circumstances. He/she shall report any such modification to the Board of Directors at its next meeting.

**SECTION IV**

The President may fill any vacancy in the Board of Directors occurring during the year by the election of an Associate Senior Member to hold office until the next annual meeting of the Association, or until a successor is duly elected, at a special meeting called for that purpose. Any vacancy in the office of President or Vice President occurring during the year by a removal or otherwise, maybe filled by the Board of Directors. The person appointed to fill such a vacancy shall hold office until his/her successor is duly elected.

**SECTION V**

By December 1st of every year the President will schedule the winter meeting and notify the Directors of these dates.

**ARTICLE VII  
VICE PRESIDENT**

**SECTION I**

In absence of the President the Directors may designate the Vice President, to exercise any power or duty of the President.

**ARTICLE VIII  
THE SECRETARY**

**SECTION I**

The Secretary shall give notice of all meetings to the members and the Directors, and shall be custodian of the seal of the Association. He/she shall perform such other duties as the Directors may, from time to time, assign to him or her.



**ARTICLE IX  
THE TREASURER**

**SECTION I**

The Treasurer shall collect all monies due to the, Association, shall have the care and custody of, and be responsible for, the funds of the Association, which he/she shall deposit in the name of the Association in a bank or place of deposit. He/she will have the custody of all the securities of the Association, which he/she shall deposit in safe deposit boxes and keep proper books of account, showing the disposition of all funds that may pass through his/her hands. In writing, he/she shall make a full report, covering the financial condition of the Association at the annual meeting of the Association and at other times as requested by the Board of Directors. The Treasurer shall be bonded and the Association shall pay the bonding fee.

**ARTICLE X  
DIRECTORS**

**SECTION I**

The Board of Directors shall be composed of four members. Three members shall be elected for a two year term by the MAWHC general membership at the annual meeting, and the fourth being the immediate past president of the organization. There shall also be two junior directors elected for a one-year term by the junior members. No more than two blood relatives and/or immediate family, residing in the same household, may serve as Senior Directors at the same time. Youth directors must be 14 to 18 years of age.

**SECTION II**

The Directors shall manage all affairs. The Directors shall make and enforce the rules and regulation governing the holding of horse shows by member clubs, the adjustment of disputes among such members or between such members and exhibitors, and such other rules and regulations as they may deem expedient for the promotion of the objects of this Association. They shall have the full authority to enforce the Constitution, rules, and regulations and decide all matters in relation thereto.

**SECTION III**

The President may at any time call a meeting of the Board of Directors, or shall do so at the request of three Directors.

**SECTION IV**

At all meeting of the Board of Directors, five of its members shall constitute a Quorum.

**SECTION V**

The Directors may impeach the President or Vice President by a 2/3-majority vote.

**SECTION VI**

Directors shall be elected or impeached by a simple majority vote of Associate Senior Members.

**SECTION VII**

The Directors may remove from office any Director who has accumulated three absences of planned meetings.

**ARTICLE XI  
COMMITTEES**

**SECTION I**

Committees as required to be appointed by the President with the approval of the Board of the Directors.

**ARTICLE XII  
MEETINGS**

**SECTION I**

MAWHC will hold bi-annual meetings. In addition to the annual club seminar meeting the winter meeting will include regular business for the Membership. The fall meeting would include the Awards Banquet and election of the Officers and Board of Directors. The Board of Director will give at least two weeks notice to all Member Club and Associate Members of the bi-annual meetings. The fiscal year shall end November 30.

## **SECTION II**

Emergency meetings may be called by the President or four (4) Directors, but only in total emergencies. This must comply with Article X, Section 4.

## **ARTICLE XIII POINT SECRETARY**

### **SECTION I**

The Point Secretary shall maintain points earned by the Association Members from all MAWHC approved shows throughout the year. These points will be for Year-End Awards. A file will be kept on points earned towards COR's for horses and ponies. The President will appoint the Point Secretary. He/she shall also maintain the current list of Club Membership.

### **SECTION II**

Upon written request the Point Secretary will inform exhibitors of only their individual points. A self-addressed stamped envelope will accompany this request.

## **ARTICLE XIV DISCIPLINARY ACTION**

### **SECTION I**

The Directors of MAWHC will handle all disciplinary action. Any and all action deemed necessary up to and including suspension of membership, and suspension or forfeiture of points and awards. Defendant will be allowed a hearing.

## **ARTICLE XV CONSTITUTION AMENDMENT**

### **SECTION I**

Notice of Amendment of the Constitution shall be given to all members and delegates two weeks prior to the annual meeting.

### **SECTION II**

Amendments may be initiated by the Board of Directors, membership or by the Delegates.

### **SECTION III**

Amendments shall be made if passed by a two-thirds vote of the members and Delegates present at the Bi-Annual Meetings or special meeting.

## **ARTICLE XVI VOTING PROCEDURE FOR OFFICERS AND DIRECTORS**

### **SECTION I**

At the annual fall meeting, nominations will be taken for the office of President. A ballot vote is taken by the membership. The nominee who receives the most votes is elected to that position. This same procedure is taken for the Vice President, Secretary, Treasure, and any director's position that needs to be filled.

### **SECTION II**

A director at the end of his first year may run for an officer's position. If that director receives an officer's position, anew director will be elected to fill his position.

### **SECTION III**

At the end of each year the President moves to the position of past President and is the eighth director of the board.

## MAWHC RULES AND REGULATIONS

### SHOW APPROVALS

1. A club/farm seminar meeting will be held after the current show season. Member clubs/farms must have delegate in attendance at this meeting to receive approval to hold a MAWHC approved show or shows during the next calendar year.
2. The first approved show date of the season shall be the weekend nearest the 15th and 16th week of the year. The last approved show date shall not be later than the first weekend after October 1.
3. Member Clubs desiring a show approval from MAWHC will be allowed a choice of one show date to be applied for applications, including dues, must be made at the mandatory Club Seminar. All clubs must be a senior member of MAWHC. If available additional show dates will be allowed. (Clubs with established extra show dates will be allowed to keep them providing there are no conflicts with other clubs "first" show requests), and they are approved at the mandatory meeting. MAWHC reserves the right to approval or deny any request from member club/farms to put on a horse show.
  - a. A club may have a double point show if a fee of \$50.00 is paid per show. All showbills and judge's to be approved at the Club Seminar Meeting by the Board of Directors. With only a one-day show approval, contest events can be run the night before as long as it does not conflict with an established show date.
4. Upon tentative MAWHC approval, Club Secretary shall submit Show Approval forms to the Show Secretary accompanied by remittance of fees for each day of the proposed show(s), by February 1st.
  - a. There will be a \$25.00 per club membership fee. This fee allows the member club to hold one (1) MAWHC approved show date. A member club may hold additional show dates, however, each additional show date requested by the club will cost an additional \$25.00 fee per date. Show fees will cover the costs accrued by MAWHC for all show(s) materials and advertisements the member club will receive to put on an approved show.
    1. Rulebook copies for hosting club and show judge(s)
    2. Entry Cards
    3. Laminated copies of all Reining patterns from rulebook for posting at shows.
    4. Laminated copies of description/rules for Leadline, Pee Wee , Green Horse or Green Rider & Pony Division classes for posting at shows.
    5. Club's showbill will be posted in MAWHC Spring Showbill Booklet
5. Applications for final approval must include:
  - a. Complete list of all classes in the entire show.
  - b. Name of proposed judge for the show and judge's qualifications.
  - c. MAWHC will need the name, address and phone number of Club Secretary or Show Manager.
  - d. All show bills shall state the entry fees and prize- (monies) offered in each class. Prize monies may be paid to at least four places in all approved performance classes, except horsemanship and equitation. Prize money may be paid to at least four places in all approved halter classes except showmanship at halter. If prize money is offered ribbons may be deleted for the first four places unless stated otherwise. Clubs are to have minimum pay back of:  
\$2.00 class -\$8.00, \$6.00, \$4.00, \$2.00;  
\$3.00 class - \$12.00, \$9.00, \$6.00, \$3.00;  
\$4.00 class -\$16.00, \$12.00, \$8.00, \$4.00;  
\$5.00 class -\$20.00, \$15.00, \$10.00, \$5.00.  
Exception: The trophies and prizes offered must be listed on the show bill and must be presented regardless of how many are in class. A gate fee of \$1.00 maximum may be charged per vehicle.
  - e. All high point exhibitor contests must be stated on the show bill. Rules for the exhibitor contest will be discussed with and approved by the MAWHC Board of Directors.
  - f. **It is strongly encouraged that member clubs provide exhibitors with two (2) copies of a back number. This allows the number to displayed on both sides of a saddle pad and be viewed easily by a judge.**

### LOCATION AND TIME

6. All shows must begin at 8:30 a.m. No performance events may begin before 11:00 a.m.

7. No contesting will be approved before 12:00 p.m. If a second ring for contesting is to be used, the starting time shall be stated on the show bill. If contesting events are held in the evening prior to the remainder of the show, the Member Club may set the time to begin these events.

## **SHOW COMMITTEE**

8. For each club shall appoint a Show Committee approved show consisting of the Show Chairman or Manager, Secretary, Ringmaster, Gate person and shall instruct them in their duties.

### **Show Committee Responsibilities**

9. Show bills must be mailed to Show Secretary no later than the second meeting of the show year. Judge's name must appear on show bill.
10. Clubs must establish a show office with mailing address and phone number. (All mailing addresses and records must be kept for one year, and must be available to the Association for inspection).
11. If a show date is reserved and not used, the following year the club will forfeit that date.
12. All point-approved classes are to be judged under the current rules of the MAWHC.
13. Rules pertaining to all classes shall be available for reference at all approved shows.
14. The show committee shall be responsible for the smooth, safe, and dignified operation of the show.
15. **An MAWHC Board approved judge must officiate each point-approved class including Contest Classes.** Exception: Unless Contest Referee is used. If the approved judge fails to appear at show time, the Members of the current Board of Directors who are present at the show will have the authority to appoint a competent person to act as substitute judge for that show. In case of emergency, a qualified member of the Board of Directors may judge.
16. The show committee shall be responsible to see that the judge's fees are paid before they can judge a MAWHC Show.
17. The Show Committee shall instruct the announcer to avoid any comments that would sound like prejudging a class or influencing the Judge.
18. The Show Committee shall maintain the right to refuse the exhibitor the privilege of showing in any event if the exhibitor's conduct should be deemed unsuitable to the dignity of the show; or should his or her horse be considered dangerous to the welfare of any participants or spectators at the show.

## **RINGMASTER**

19. The Ringmaster shall be familiar with show and contest procedures. He/she shall check equipment set up for events; see that horses in the ring are properly placed, etc.
20. The Ringmaster must have in mind that he/she has been selected to help the Judge, but not advise him. He/she shall not take part, or appear to take part in any of the judging. When not engaged in his/her duties, he/she shall place himself in such a position so as not to interfere.
21. A Ringmaster shall not show in any class once he/she has ring mastered at that show.
22. By assembling the class promptly a good Ringmaster makes the work of the Judge much easier. He/she will be able to keep the judging program on schedule and eliminate long delays between classes.
23. The Ringmaster should dress in appropriate attire.

## **SHOW STEWARD**

24. The Show Steward shall be any Board Member present on the show ground during the show.
25. The Show Steward will decide on any disputes concerning show rules and procedures.

## **SHOW SECRETARY**

26. The duties of the Show Secretary shall include the following:
  - a. Complete the show approval form and submit it to the Association Show Secretary.
  - b. Submit show bills to the Association Show Secretary at least 45 days prior to the show.
  - c. Supervise the entry booth.
  - d. Report points earned to 6 places, and the actual number of horses in each point approved class, including name of horse, owner and Exhibitor. This report shall be made to the Association Point Secretary within 10 days after completion of the show. Show bill is to be included. Failure to comply subjects club to a fine of \$10.00.
27. A Show Secretary shall not show at a show during which he/she is the Show Secretary.

## **TIMER**

28. The Official Timer is the senior timer who reports the time to the Judge and the Announcer. No Official may time a relative or member of his immediate family, or his/her mount.
29. An electric timer may be used, or two stopwatches with the average time of the watches used by the Timers to be the official time. When electric timer is used, a stopwatch must also be used in case of failure of electric timer. Official Timer must read electric timer. Official may not show in contest classes.

## **JUDGE**

30. Show committees are encouraged to have a Junior Judge with the Show Judge but only the Show Judge makes final decisions.
31. The minimum age for Junior Judges shall be 18 years. Senior Judges must be 21 years and over. Judging qualifications for judging a MAWHC approved show:
  - a. A judge should hold a breed card that requires yearly testing and annual seminars. Judges not holding a breed card or holding only a 4-H card may not be accepted.
  - b. A judge must have judged a minimum of ten (10) horse shows of MAWHC quality.
  - c. Both of these are qualifications that are subject to Board approval.
32. A Judge shall not:
  - a. Judge a class in which a member of his/her family or any of his/her horses are competing.
  - b. Judge more than one (1) MAWHC approved show per year.
  - c. A Judge shall not exhibit in a MAWHC approved show prior to judging a MAWHC show in that show season.
  - d. Judge an approved show for a club of which he is a member.
  - e. Be a houseguest of an Exhibitor or his/her family during the period of a show he is judging.
  - f. Judge any horse that has within six (6) months, been sold by him/her or his/her employer.
  - g. Judge a horse of an Exhibitor with whom he/she has had, within six (6) months, a financial arrangement for a sale, purchase, lease, or for the account of any horse.
  - h. Discuss the purchase, sale or lease of any horse during the show.
  - i. Appear on the show grounds more than 15 minutes prior to the time set for the show to start.
  - j. Visit with owners or Exhibitors, visit in the barns, or assembling areas; nor inspect or discuss any horse entered in the show or contest except in the actual judging of a class, until after the judging is completed.
  - k. Place a horse that he/she considers being unsound.
  - l. Judge a MAWHC show, if he/she is currently on the MAWHC Board of Directors, except in the case of an emergency.

33. A Judge will be penalized for infractions of rules by suspension, subject to action of the Directors.
34. The Judge shall judge each class:
- a. In conformity with the rules and regulations set forth for each class in the current MAWHC Rule Book.
  - b. With promptness and dispatch and not appear indecisive. Any questions to be asked must be asked in the presence of Ringmaster or Show Steward. There will be no questions asked of the Judge by an Exhibitor in the ring without the Judges permission. Permission is granted by asking the Ringmaster to ask the Judge for his/her privilege.
  - c. Any judge maintains the right to dismiss anyone who he/she feels is acting in a disrespectful manner or obstructing class proceedings.

### EXHIBITORS AND FAMILY

35. The term "Exhibitor," when used herein refers to:
- a. The owner, lessee, or handler of a horse entered in a class where the merits of the horse are to be considered.
  - b. In Horsemanship and Equitation classes the "Exhibitor" is the rider.
36. No Exhibitor may show before a Judge any horse under said Judge's family ownership or lease.
37. **No Exhibitor may compete in an approved class before a Judge/family by whom, within six (6) months of the show:**
- a. **He/she has been instructed, coaches or tutored, with or without pay.**
  - b. **His/her parents, guardian or instructor have had financial transactions relative to the sale, lease, board or training or any horse. (The conducting of clinics or assistance in-group activities will not be considered as instructing, coaching or tutoring.)**
38. Along with a \$25.00 protest fee an Exhibitor may present in writing any legitimate protest concerning the Judge, Show Committee, Ringmaster, etc. to any Board Member within 48 hours of said protest. If the Board deems your protest valid the money will be refunded. You must protest within 14 days of an alleged violation of the rules to the board. Anonymous protests will not be considered a valid protest.
39. The term "Family" when used herein shall mean two head of household adults, or a single parent head of household, and any children living within the same household.

### POINTS AND AWARDS

40. To accumulate MAWHC points, the exhibitor must belong to MAWHC. Membership fees per year are \$20.00 for individual membership and \$35.00 for family membership. (*\*see #39 above for family definition*)
41. A nomination form must be completed on each horse/pony to accumulate points. Points earned before form has been submitted will not count. There is no nomination fee unless horse/pony is switched/added mid-year, a fee of \$5.00 per horse/pony must be paid prior to the accumulation of points. Points earned before fee has been paid will not count.

Number of Horses	Points
1	1
2	2,1
3	3,2,1
4	4,3,2,1
5	5,4,3,2,1
6-11	6,5,4,3,2,1
12 or over	12,10,8,6,4,2
(Double points for 12 or more per class)	

42. Points will be awarded in all approved classes held at approved shows in the following manner

43. Points for the current year are to be posted monthly on the Club Website: <http://www.mawhc.tripod.com> A hardcopy will be published once, mid-season.
44. To receive a Year End Award the nominated horse or paid member, with the most points, wins the award in that class. The class has to be offered at least 50% of the shows, and the exhibitor must show 5 times per individual class to qualify for a year end award in that class. (*\*See pages 40-43 of the rule book for additional Hi Point and Special Award criteria's and/or qualifications for year end awards.*)
- a. To receive an Award a paid member must contribute to the club in one of the following ways:
    1. Work or get a worker for a job at the Board of Director show or other MAWHC approved function. MAWHC will provide a list of the jobs needed to be done at this show or other functions.
      - a. 4 hours of time must be worked. Time may be split up into 2-hour lots at separate approved functions. (*example: 2 hours worked gate at fun show & 2 hours worked entry office at Board show*)
    2. Participate in an MAWHC fundraiser
    3. Submit \$50 in sponsorship (*All sponsorships must be submitted by August 1<sup>st</sup> of current show year*)
  - b. Ties will be decided by the most show attended, then by the highest placings.
  - c. To receive an award the exhibitor must be in good standing with all affiliated groups. For further information see Article XIV Section 1 (Disciplinary Action).
45. The Total number of points accumulated at approved shows, throughout the year, shall determine the Grand Champion and Reserve Champion plus honorable mentions for the next 4 places in each class. If no Exhibitor or Horse qualifies, no Championship or Reserve Championship will be awarded in that class.
46. The Annual Grand Championship, Reserve, and Certificate of Recognition (C.O.R.) are the top awards of the MAWHC.
47. Horsemanship, English Equitation, and Showmanship at Halter points are awarded to the Exhibitor, regardless of whether they show one or more horses during the season. In all other show and contest classes, the horse earns points, if shown by an Associate Member.
48. Recipients of the Shinville Award, past and present, will receive Life Membership of the MAWHC. Those award recipients will be published within this Rulebook.

#### **CERTIFICATE OF RECOGNITION (C.O.R.)**

49. The purpose of the Certificate of Recognition is to establish a record of show performance. Horses shall be listed in C.O.R. as soon as they receive points in approved shows. Before the points will be counted a nomination form must be completed.
50. To qualify for C.O.R. points, the exhibitor must be an associate member of the MAWHC.
51. Number of points required to receive a C.O.R. in each separate class per approved division is as follows:
- |                      |            |
|----------------------|------------|
| a. Halter Division   | 100 points |
| b. Pleasure Division | 200 points |
| c. Reining Division  | 20 points  |
| d. Contest Division  | 20 points  |
| e. Open Performance  | 35 points  |
| f. Open Reining      | 20 points  |
| g. Pee Wee Division  | 50 points  |
| h. Pony Division     | 40 points  |
52. Points earned within one year
53. A horse will receive only one C.O.R. per division but may work toward a C.O.R. in any of the other division. Division is defined as all classes within that category (i.e. English Halter, Quarter Horse Halter, Reg. Mare Halter, points to be combined from all halter classes to earn 100 pts for a Halter Division COR). C.O.R. Awards will be made at the Annual Award Meeting. If the horse is sold, the current owner is eligible to receive a C.O.R.

**54. List of all Optional classes.**

Reg. & Non Reg. Weanling and Yearling Halter  
Reg. & Non Reg. 2 & 3 Year Old Halter  
Reg. Appaloosa Horse Halter  
Reg. Color Horse Halter  
Reg. Fine Horse Halter  
Reg. Paint Horse Halter  
Reg. Quarter Horse Halter  
Open English Horse Halter  
Miniature Horse Halter  
Pee Wee & Lead Line Showmanship Horse/Pony (10 & Under)  
Open Pony Showmanship  
Showmanship 13 & Under  
Showmanship 14 -18  
Showmanship 19 & Over  
Open Pony English Equitation  
Pee Wee Walk/Trot Horse/Pony English Equitation 10 & Under  
English Equitation 13 & Under  
English Equitation 14 -18  
English Equitation 19 & Over  
Pee Wee Walk/Trot Horse/Pony Horsemanship 10 & Under  
Open Pony Western Horsemanship  
Western Horsemanship 13 & Under  
Western Horsemanship 14 -18  
Western Horsemanship 19 & Over  
Green Horse or Green Rider  
Over 30  
Reg. Appaloosa Horse Saddle  
Reg. Color Horse Saddle  
Reg. Fine Horse Saddle  
Reg. Paint Horse Saddle  
Reg. Quarter Horse Saddle  
Non-Registered Horse Saddle  
Open Reining  
Open Trail  
Open Cloverleaf  
Open Down and Back  
Open Cross Rail  
Open Over Fences

**55. List of All Mandatory Classes**

Reg. Mare Halter  
Reg. Gelding Halter  
Reg. Stallion Halter  
Non-Registered Horse Halter  
Open Pony Halter  
Pee Wee & Lead Line Halter Horse/Pony (10 & under)  
Pee Wee Walk/Trot Horse/Pony Western Pleasure 10 & Under  
Pee Wee Walk/Trot Horse/Pony English Pleasure 10 & Under  
Pee Wee Walk/Trot Horse/Pony Performance 10 & Under (Pattern Required)  
Lead line 6 & Under (No other riding class allowed)  
English Pleasure 13 & Under  
English Pleasure 14 -18  
English Pleasure 19 & Over  
Open Pony English Pleasure  
Open Pony Western Pleasure  
Open Performance (Pattern Required)  
Senior Horse/Pony Pleasure 6 & Over  
Junior Horse/Pony Pleasure 5 & Under  
Western Pleasure 13 & Under



Western Pleasure 14 -18  
Western Pleasure 19 & Over

- a. A show committee may combine like age division classes if there are less than 3 exhibitors signed up for the class. All exhibitors must agree to the combination.  
Example: Eng. Pleasure 14-18 and Eng. Pleasure 19 & Over combined

**GENERAL RULES FOR JUDGED EVENT  
(See Division Topics for Exceptions)**

56. No rules will be changed after May 1st or the start of the show season.
- An Exhibitor or contestant must show in the proper age classification. The Show Committee at an approved show may request proof of age.
  - An Exhibitor is responsible for his/her eligibility in any class. Upon improper entry, an exhibitor from the day of the violation forfeits entry fees, points and prizes. The exhibitor will also be suspended for 30 days from all approved shows.
57. For horse show purposes, the age of the Exhibitor or contestant on January 1st of the current year shall be considered his/her age for that entire show season.
58. All horses must be 14 hands or over, or will mature to 14 hands or over.
- No horses will be assisted into the show ring.
59. No discrimination will be shown between any Western type horse as to color or breed, except such events, which are specifically for horses of certain types, breeds, or colors.
60. In all Western events, western hat, boots, and western type pants must be worn. Collar type blouse or shirt, with long sleeves, must be worn (no t-shirts, sweatshirts, or tank type shirts or blouses). Spurs are optional to the Exhibitor; chaps are optional to the Judge. Proper attire shall be maintained until after exiting the show ring.
- Western boots worn must have a riding heel and be smooth soled for safety; it is the judge's discretion to allow rough out soles for riding purposes.
61. In all English events proper appointments are required. Neatness is the first requisite and the following requirements are based on tradition and present day customs. Judges may eliminate those contestants who do not conform. The mandatory requirements for Hunt and Saddle Seat appointments are listed as follows:

**GENERAL RULES FOR JUDGED EVENT CONTINUED**

**A. Hunt Seat**

- Suitable show-hunter riding coat. May be wool and/or summer weight qualities. Color must be dark solids, tweeds or conservative patterns.
- Red (Pinque) Coats are prohibited, unless earned, with proof at hand.
- Hard hunting hats (caps or derbies).
- Hunt type collar blouses or shirt.
- Choice of breeches and high English boots, or jodhpurs and Jodhpur boots.
- Hair must be neat and contained in net or braid.
- Flower in lapel is prohibited.
- Long earrings are prohibited.
- Gloves are preferred.
- 10. Proper attire shall be maintained until after exiting the show ring.**

**B. Saddle Seat**

- Either informal or formal attire is acceptable.
- Saddle suits are acceptable.
- Ties are required
- Gloves are preferred.
- Hair must be neat and contained in net or braid.

6. Long earrings are prohibited.
7. Proper boots required.
8. Derby types hat required.
9. **Proper attire shall be maintained until after exiting the show ring.**

62. Horse may have only one rider per class.

63. Drug Usage: No person shall cause to be administered internally or externally to a horse, either before or during an approved event, any medication which is of such character as could affect its performance, including masking agents. Any MAWHC member may ask for a drug test on a specific horse contingent upon compliance of the following steps:

- a. A \$100.00 drug-testing fee paid directly to, MAWHC immediately upon the request for testing.
- b. The requesting member shall have a Michigan licensed veterinarian on hand for immediate collection of blood and urine sample.
- c. The samples shall be processed through a qualified lab.
- d. Positive Drug Test Result Penalty: The Board of Directors shall meet to discuss penalties to be assessed if sample is positive. Penalties include, but are not limited to, suspension of member and horse. Failure of compliance by the owner of the horse requested to be tested shall imply guilt. The member requesting test shall pay for the veterinarian's time and services; MAWHC shall pay for the lab analysis.

64. The Judge shall have the right to eliminate any horse from the show ring whose manner is deemed unsafe to other horses or riders. The Judge's decision shall be final in all cases.

65. Non-registered horse: Entries will be accepted for any horse that will mature to 14 hands or over, and is not registered or eligible for registry.

66. Definition of a registered horse: A horse that is registered by a recognized Breed Association or is eligible for registration, or if registration is applied for. Exception: Young horses- whose Breed Association requirements do not demand registration until a later age. Evidence of it must be presented upon demand.

67. Stallions shall not be allowed to be shown by youth.

#### **HALTER** **(General)**

##### **(See Division Topics for Exceptions)**

68. Horses are to be shown at a walk and trot and are to be judged on conformation, finish, manners, and way of going. Transmissible weakness and/or unsoundness shall be counted strongly against animals. Small blemishes, on account of accident will not be counted against the horse.

69. Whips are allowed in all halter/showmanship classes according to Breed rules.

70. Horses may be shown Western or English with proper tack and attire, not to be mixed.

**a. English**

All horses must be shown with English type halters or bridles. Saddle seat in full bridle and hunt seat in hunt bridle

**b. Western**

All horses must be shown in a Western type halter.

71. Horses shall be allowed to set according to its breed type.

## **HALTER BREED EXCEPTIONS**

### **QUARTER HORSE HALTER**

72. To compete in the MAWHC approved Quarter Horse halter class horses in this division, yearling or older must be registered with American Quarter Horse Association of Amarillo, Texas or associations approved and recognized by the AQHA. Application for Registration is to be shown at time of entry registration.

- a. Stallions and mares weanlings may be exhibited with either a numbered Registration Certificate, or a new Appendix Certificate.
- b. This is a Western attire only class.

### **APPALOOSA HORSE HALTER**

73. Any horse that is registered with the ApHC (Appaloosa Horse Club) or any association that is approved by the ApHC will be eligible to show in the Appaloosa Horse Halter.

- a. Halter Classes are to be judged as follows: 60% Conformation, 20% Type, and 20% Action.
- c. No coloring of the hooves will be permitted that would cover and/or hide the natural characteristics of the hooves. Clear hoof dressing will be allowed.
- d. This is a western attire only class.

### **REGISTERED FINE HORSE HALTER**

74. To compete in MAWHC approved halter class in this division, horses must be registered with one of the following associations or associations approved and recognized by the: Arabian Horse Registry of America, Inc., International Arabian Horse Association Half Arab Registry, American Morgan Horse Association, American Saddlebred Association, Paso Fino Horse Association Inc., Tennessee Walking Horse Association, Gaited Horse International Association, Friesian Horse Association and American Hackney Society. Association breed rules and standards will apply. Registered horses whose Association is not listed above and are deemed a "Fine Horse" may be allowed in the Fine Horse Division classes pending board approval.

- a. English or Western Exhibitors may participate, but clothing and tack may not be mixed.

### **REGISTERED COLOR HORSE HALTER**

75. This class is to be judged as follows:

25% Color, 75% Conformation and Way of Going. To be eligible to compete in MAWHC approved halter classes horses in this division two years or older must be registered with a national corporate color registry.

- a. English or Western Exhibitors may participate, but clothing and tack may not be mixed.

### **REGISTERED PAINT HALTER**

76. To be eligible to compete in the MAWHC approved halter class horses in this division yearling and older must be registered with the American Paint Horse Association of Fort Worth, Texas or associations approved and recognized by the APHA.

- a. Any horse that is registered with the APHA (American Paint Horse Association) will be eligible to show in the Paint Horse Division.
- b. Judging standards shall be the same as Registered Color Halter Division above.
- c. This is a Western attire only class.

### **NON REGISTERED HORSE HALTER**

77. This is a horse only class. To compete in MAWHC approved halter class in this division, horses must be over 14 hands and not be registered with any recognized breed or approved association.

- a. English or Western Exhibitors may participate, but clothing and tack may not be mixed.

### **OPEN SHOWMANSHIP AT HALTER**

78. To be judged strictly on the Exhibitor's ability to fit and show. The horse is the means through which a contestant exhibits his or her ability to show a horse at halter; therefore, no considerations shall be given to the horse other than fitting and grooming. The purpose of a showmanship class is to train and prepare Exhibitors as to the proper manner of showing horses at halter.

- a. English or Western Exhibitors may participate, but clothing and tack may not be mixed.
- b. Judging techniques and procedures will vary according to individual Judges' preference. .

79. All showmanship rules will apply to judging pattern. A suggested judging guideline is as follows:

**Exhibitor -20%**

- a. Personal appearance must be neat and clean.
- b. Suitable clothing must be worn.

**Fitting and Grooming -30 %**

- a. Tack; Clean halter adjusted to fit and lead strap or rope to be 6 or 7 feet long.
- b. Horse should be clean and well groomed. Long hairs inside ears and jaws, fetlocks and lower legs should be trimmed.
- c. Main and tail must be clean and free of tangles.
- d. Horse's feet should be trimmed and clean, or properly shod with clinches neat.

**Showmanship -50%**

- a. The Exhibitor must be attentive and courteous.
- b. The Exhibitor shall always lead the horse from the horse's left side. (Near side).
- c. Enter the ring at a brisk walk in a counter clockwise direction. Walk on the horse's left side with your right hand on the lead strap about 6 to 12 inches from the halter. The remaining portion of the lead strap should be held in the left hand.
- d. When lining up, stand your horse according to breed type. Stand at the left or near side of horse's head, facing horse, but always in a position to keep your eye on the Judge.
- e. From the line, each Exhibitor will be called upon to travel his horse individually. When traveling the horse at a walk or trot, remember to keep body to one side so as not to block the Judge's view of horse's legs. When turning (right), hold right arm straight out, moving close to halter, and begin walking to the right around horse's body in a circle. If the turn is made properly, the horse will stand squarely in his own tracks, facing the right direction. After walking horse, set him squarely in front of the judge for inspection. On being released, move to position in line.
- f. Keep proper position in line, allowing reasonable space between horses. Keep an eye on horse, and be aware of Judge's position. Continue showing until the entire class is placed.

**Faults**

- 1. Failure to recognize and correct faults in horse's position.
- 2. Kicking horse's legs into position.
- 3. Failure of horse to lead properly and to stop before turning.
- 4. Turning in wrong direction.
- 5. Loud voice commands to horse.
- 6. Over-showing, under showing.
- 7. Blocking Judge's view, or causing Judge to move to avoid being stepped on.
- 8. Improper equipment or attire.

**WESTERN HORSEMANSHIP DIVISION**

80. Western horses shall be shown with stock saddle, western bridle, grazing, snaffle, curb, half-breed, bar or spade bit, braided rawhide, leather or cape bosal Hackamore. No iron will be allowed under jaw, regardless how padded or taped. No chinstrap narrower than one-half inch will be permitted. Chain curbs are permissible, but must meet the approval of the Judge, and it must be at least one-half inch in width, lying flat against the jaw of the horse. Two hands are allowed on junior horses only ridden with a snaffle bit or bosal. Two-year-old horses can not be shown before July 1st of the current show year.

81. Split reins or romal reins may be used in all western classes. If split reins are used, only one hand will be permitted on the reins and hands must not be changed. Ends of split reins shall remain on near side at all times. One finger between reins will be permitted. While the horse is in motion, rider's hands must be clear of the horse and saddle. If romal reins are used, the extension can be carried in the free hand with a 16 inch spacing between the reining hand and the free hand holding the romal. The romal shall not be used forward of the cinch or used to signal or cue the horse in any way. Any infraction of this rule shall be penalized severely by the judge.

82. Offering of money prizes in Horsemanship Classes is forbidden, since the rules covering international sports state: "A competitor accepting money prizes thereby becomes a professional." In horsemanship, the individual is the competitor and wins the award.

83. Rider will be judged on his/her: hands, performance of horse, and suitability of horse to rider. Results as shown by the performance of the horse are to be considered more important than the rider's method used in obtaining them.
84. Hands: Both hands and arms shall be held in a relaxed easy manner, with upper arms to be in a straight line with body. The hand holding the reins bent at elbow. Freehand will be partially closed and held near the belt with elbow bent, causing the hand to be near but not against the body in front of the side. However, when using a romal, the rider's off hand shall be around the romal with at least 16 inches of slack. Some movement of the arm is permissible, but excessive pumping will be penalized. Hands to be around reins. When using split reins one finger between reins is permitted, but not with romal reins. Reins should be carried so as to have light contact with horse's mouth, and at no time shall reins be carried more than a light hand movement from the horse's mouth.
85. Position: The rider should sit the saddle with knees slightly bent and weight directly over balls of the feet. The stirrup should be just short enough to allow rider to be comfortable, relaxed, and flexible. Rider should set the jog and not post. At the lope he/she should be close to the saddle. All movements of horse should be governed by the least amount of cues possible, and the shifting of the rider's weight is not desirable.
85. Class Routine: Horses are to enter at a walk or at the Judges discretion. They are to be judged at a walk, jog, and lope. They will be worked both ways of the ring on the rail, and shall always be on the correct lead. The horse should be in perfect balance at all times, working entirely off his haunches, mouth closed, and head at normal height. It must be remembered that, above all, a stock horse is one that responds instantly and smoothly to all cues. Except for riders 13 & under, riders can be asked to dismount and mount. Changing of horses, due to difficulty of properly fitted tack, is prohibited. **Riders should be able to perform whatever additional tests the Judge may deem advisable. All finalists shall be required to back in a straight line. Judge may ask for individual work-offs at his/her discretion.**
- a. If a pattern is used rail work is optional at the judge's discretion
87. If Judge asks the entire class for individual work-off of the rail, he/she must post the pattern for at least one hour prior to the commencing of the class.
88. Spurs are optional to the rider, and chaps are optional to the Judge.

**WESTERN PLEASURE DIVISION GENERAL RULES**  
**(For Exceptions See Below)**  
**>Breed Rules Apply<**

89. Western horses shall be shown with stock saddle, western bridle, grazing, snaffle, curb, half-breed, bar or spade bit, braided rawhide, leather or cape bosal hack amore. No iron will be permitted with Hackamore, no matter how taped or padded. Nose bands, choke ropes, tie downs, or running martingales and jerk lines are not permitted. No iron will be allowed under jaw, regardless how padded or taped, or no chinstrap narrower than one-half inch will be permitted. Chain curbs are permissible, but must meet the approval of the Judge, and must be at least one-half inch in width, lying flat against the jaw of the horse. Two hands are allowed on Equine Exhibit ridden with a snaffle or bosal. Two-year-old horses can not be shown before July 1st of the current show year.
90. Split reins or romal reins may be used in all western classes. If split reins are used, only one hand will be permitted on the reins and hands must not be changed. Ends of split reins shall remain on near side at all times. One finger between reins will be permitted. While the horse is in motion, rider's hands must be clear of the horse and saddle. If romal reins are used, the extension is allowed to be carried in the free hand with a 16 inch spacing between the reining hand and the free hand holding the romal. The romal shall not be used forward of the cinch or used to signal or cue the horse in any way. Any infraction of this rule shall be penalized severely by the judge.
91. Horses must be sound (soundness determined at Judge's discretion).
92. This class to be judged as follows:

20% Conformation, 60% Performance, 20% Appointments.

93. Horses are to be shown at a walk, jog, and lope with reasonable loose rein, without undue restraint. Judge may ask for added performance suitable to pleasure horses. Judges will not ask for an extend lope of more than 8 Exhibitors at a time.
94. The Judge should give credit to a smooth, easygoing horse. Credit should also be given for the proper method of putting a horse into its leads.
95. Every Exhibitor must have the privilege of working his horse both ways of the ring on the rail at a walk, jog, and lope.
96. A Judge must, if asking for a false lead, allow the horse to start at least 15 feet from the rail. When class competition is tight and judging is difficult, the Judge<sup>125</sup>. Prohibited Appointments: Boots of any description, on the horse, draw reins or martingales, artificial appliances, and Western Saddles. When class competition is tight and judging is difficult the Judge may ask some or all of the Exhibitors to dismount and check equipment.
97. While the horse is primarily judged, the attire, showmanship, and ability of the rider are also to be considered.
98. Horse shall be shown with a stock saddle. Silver equipment will not count over a good working outfit.
99. A bosal or a curb snaffle, half-breed, or spade bit is permissible. Chain curbs are permissible, but must meet the approval of the Judge, must be at least one-half in width, and must lie flat against the jaw of the horse.
100. No wire curbs, regardless of how padded or covered, nor any chain strap narrower than one-half inch will be permitted. A martingale or tie down is prohibited.
101. Use of a rope or riata is optional. If used, the rope or riata must be coiled and attached to the saddle. If romal reins are used, hobbles are required.
102. Horses shall not be asked to reverse at the lope.
103. All finalists are to be asked to back.
104. Reins should be carried with light contact to the horse's mouth. At no time shall reins be carried more than a slight hand movement from the horse's mouth.

#### **Exceptions**

105. **Junior Horses, competing in Western Pleasure Classes and Saddle Classes that are shown with a Hackamore or snaffle bit, may be ridden with two hands on the reins. Breed Rules do apply.**

#### **REGISTERED QUARTER HORSE SADDLE**

106. To compete in MAWHC approved quarter horse saddle classes horses in this division two years of age or older must be registered with the AQHA, Texas or associations approved and recognized by the AQHA. Two-year-old horses cannot be shown before July 1st of the current show year.
- c. This is a Western attire only class.

#### **REGISTERED APPALOOSA HORSE SADDLE**

107. Any horse that is registered with the ApHC (Appaloosa Horse Club) or any association that is approved by the ApHC will be eligible to show in the Appaloosa Horse Division. Breed rules will apply.
- a. This class is to be judged as follows:  
60% on Performance and Manners, 30% on Confirmation. Quality and Substance, 10% on Appointments
- b. This is a Western attire only class. Chaps are optional per breed rules.

### **REGISTERED PAINT HORSE SADDLE**

- 108.** To compete in MAWHC paint saddle classes horses in this division two years of age or older must be registered with the American Paint Horse Association of Fort Worth, Texas or associations approved and recognized by the APHA before it is eligible to compete in the MAWHC approved saddle classes. Two year old horses can not shown before July 1st of the current show year.
- a. Horses shall not be asked to extend the lope.
  - b. This class is to be judged as follows: 75% Performance, 25% Conformation.
  - c. This is a Western attire only class

### **REGISTERED FINE HORSE SADDLE**

- 109.** To compete in MAWHC approved saddle classes in this division, horses must be registered with one of the following associations or associations approved and recognized by the: Arabian Horse Registry of America, Inc., International Arabian Horse Association Half Arab Registry, American Morgan Horse Association, American Saddlebred Association, Paso Fino Horse Association Inc., Tennessee Walking Horse Association, Gaited Horse International Association, Friesian Horse Association and American Hackney Society. Association breed rules and standards will apply. Registered horses whose Association is not listed above and are deemed a "Fine Horse" may be allowed in the Fine Horse Division classes pending board approval.
- a. English or Western Exhibitors may participate, but clothing and tack may not be mixed.

### **REGISTERED COLOR HORSE SADDLE**

- 110.** To compete in MAWHC color saddle classes horses in this division two years or older must be registered with a national corporate color registry to be eligible to compete in MAWHC approved saddle classes. Two-year-old horses cannot be shown before July 1st of the current show year.
- a. This class is to be judged as follows: 75% Performance, 25% Conformation. Color is to be used only to break a tie.
  - b. English or Western Exhibitors may participate, but clothing and tack may not be mixed.

### **NON REGISTERED HORSE SADDLE**

- 111.** This is a horse only class. To compete in MAWHC approved halter class in this division, horses must be over 14 hands and not be registered with any recognized breed or approved association.
- a. English or Western Exhibitors may participate, but clothing and tack may not be mixed.

## **ENGLISH EQUITATION DIVISION**

### **HUNT SEAT**

#### **GENERAL RULES**

- 112.** Tack Appointments (Required):
- a. English snaffle (no shank). Pelham (with two reins), kimberwick and/or full bridle, all with cavesson nose band and plain leather brow bands. Any deviation from regulation bits is prohibited.
  - b. Saddle: hunting or forward seat; may have suede and/or suede insert on skirt.
- 113.** A judge at his/her own discretion may penalize a horse with non-conventional type of bits or nose bands.
- 114.** Optional Appointments: spurs of the unrolled type, crops, bats, gloves, or English breast plate, and braiding of mane and/or tail in hunt style are all optional.
- 115.** Prohibited Appointments: Boots, of any description, on the horse; draw reins or martingales; artificial appliances; and western saddles.
- 116.** Seat and Hands
- a. General - Rider should have a workmanlike appearance. Seat and hands should be light and supple, conveying the impression of complete control should any emergency arise.
  - b. Mounting and Dismounting - To mount, take up reins in left hand and place hand on withers. Grasp stirrup leather with right hand and insert left foot in stirrup and mount. To dismount, rider may either step down or slide down. The size of rider must be taken into consideration.
  - c. Hands - Hands should be over and in front of horse's withers. Knuckles should be thirty degrees

inside the vertical, hands slightly apart and making a straight line from horse's mouth to rider's elbow. Method of holding reins is optional and bight of reins may fall of either side. However, all reins must be picked up at the same time.

- d. Basic Position – The eyes should be up and shoulders back. Toes should be at an angle best suited to rider's conformation, ankles flexed in, heels down, calf of leg in contact with horse and slightly behind the girth. Iron may be either on toe, ball of the foot, or "home".
- e. Position in Motion - At the walk and slow trot, body should be vertical. At the posting trot, body should be inclined forward. At a canter, position should be half way between the posting trot and the walk. Galloping and jumping, position should be the same inclination as the posting trot.
- f. If a pattern is used rail work is optional at the judge's discretion.

## **SADDLE SEAT GENERAL RULES**

### **117. Tack Appointments (Required)**

- a. Full bridles, consisting of snaffle and Weymouth or Pelhams are permitted.
- b. Saddle: Dressage, Show Cutback or Park type English saddles, and linen girths are permitted.
- c. All tack to be neat and clean.

### **118. Optional Appointments: Spurs of the unrolled type, crops or bats are optional.**

### **119. Prohibited Appointments: Boots, of any description, on the horse; draw reins or martingales; artificial appliances; and western saddles.**

### **120. Seat and Hands**

General - Judges should note that the required equitation seat should in no way be exaggerated, but the thoroughly efficient and most comfortable **for riding the type of horse called for at any gait, and for any length of time. In saddle seat equitation classes, riders should convey the impression of effective and easy control. To show a horse well, he should show himself to the best advantage. The Judges shall take ring generalship into consideration.** A complete picture of the whole is of major importance.

- a. Hands - Hands should be held in an easy position, neither perpendicular nor horizontal to the saddle, and should show sympathy, adaptability, and control. The height of the hands is held above the horse's withers, as a matter of how and where the horse carries his head. The method of holding the reins is optional, except that both hands shall be used and all reins must be picked up at one time. Bight of rein should be on the off side.
- b. Basic Position. To obtain proper position, rider should place himself/herself comfortably in the saddle and find his/her center of gravity by sitting with a slight bend at the knees, but without use of irons. While in this position, adjust leathers to fit. Irons should be placed under ball of the foot (not toe nor "home"), with even pressure on entire width of sole and center of the iron. Foot position should be natural (neither extremely in nor out).
- c. Position in Motion. Walk: slight motion in the saddle. Trot: slight elevation in saddle posting; hips under body, not mechanical up-and-down, nor swinging forward and backward. Canter: close seat, going with horse.

## **OPEN HUNT AND SADDLE SEAT GENERAL RULES**

### **121. Horses in Hunt Seat and Saddle Seat are to be Shown at a walk, trot and canter both ways of the ring unless at the judge's discretion is a pattern is used. Finalists are required to back.**

- a. It is the Judge's option to require an Exhibitor to extend any gait.
- b. They may be required to reverse at the walk, trot at the discretion of the Judge, but shall not be asked to reverse at the canter.

### **122. Horses must be brought to a flatfooted walk before changing gaits.**

### **123. Tack Appointments (Required):**



- a. English snaffle (no shank). Pelham (with two reins), kimberwick and/or full bridle all with cavesson nose bands and plain leather brow bands. Any deviation from regulation bit is prohibited.
  - b. Saddle: hunting or forward seat; may have suede seat and/or suede insert on skirt.
124. Prohibited Appointments: Boots of any descriptions, on the horse, draw reins or martingales, artificial appliances and Western Saddles.
125. Judge, at his/her discretion, may penalize a horse with non-conventional types of bits or nose bands.
126. Hunt Seat. At the option of the Judge, eight horses may be required to hand gallop collectively one way of the ring, but never more than eight at one time. At the hand gallop, the Judge may ask the group to "halt" and stand quietly on a free rein (loosened rein).
127. Tack Appointments (Required):
- b. Bridles: Full bridles, consisting of snaffle and Weymouth or Pelhams are permitted. Entries shall be shown in full bridles.
  - c. Saddle: Dressage, Show, Cutback or Park type English saddles, and linen girths are permitted.
128. Optional Appointments: Spurs of the unrolled type, crops, or bats are optional.
129. Prohibited Appointments: Martingales, tie downs, draw reins. Boots of any descriptions for use on the horse, artificial appliances, forward seat and Western saddles.
130. Judge, at his/her discretion, may penalize a horse with non-conventional types of bits or nosebands.
131. Saddle Seat is required to have an extended trot

#### LEADLINE DIVISION

132. Lead line Rules: Open to children 6 years and under with a horse or pony. Age is determined by age of exhibitor as of January 1st of current show year. This class is a non-money class.
- a. This class is to be the Exhibitors only performance class of the day.
  - b. Points in this class are to be awarded to the rider and can be used in this division only.
  - c. Exhibitors in this class may be shown in either English or Western Clothing and tack, but they must not be mixed.
  - d. A Lead-liner must be accompanied by an adult and the adult must have a separate lead from the lead-liner. In the performance class the lead must be attached to a halter. Leads may not be attached to any part of a bridle. *(exception: if a bosel is used, the macate may be used in place of the halter w/ lead. Discretion is given to the Board to approve)*
  - e. Lead-liners will be allowed in Pee Wee Halter & Showmanship classes.

#### PEE WEE DIVISION

133. Pee Wee Classes are open to children 10 years of age and under. Age is determined by age of exhibitor as of January 1st of current show year. Exhibitors in these classes are prohibited from showing in any other OPEN classes including halter, showmanship and pleasure. All Pee Wee Classes are not money classes. For safety reasons, proper tack, fitting the rider, must be required.
- d. Lead-liners are allowed to enter into the PeeWee Halter & Showmanship classes only.
134. Pee Wee Horse/Pony Halter: A horse or pony is allowed in this class. Points are awarded to the horse/pony. This class does not count towards high point halter. Certificate of Recognition points do apply for Pee Wee Division; 60 points over a 2 year period to receive COR.
135. **Pee Wee Horse/Pony Showmanship: A horse or pony is allowed in this class. Points in this class are awarded to the exhibitor. Exhibitors in this class may show in either English or**

Western clothing and tack, but they may not be mixed. The judge must post an appropriate pattern if different than pattern listed below:

- a. Walk to the judge.
- b. Set up for inspection.
- c. After inspection turn an 180 degree turn to the right.
- d. Trot back to starting point, turn and line up.

- 136.** Pee Wee Walk-Trot Horsemanship: A horse or pony is allowed in this class. Points in this class are awarded to the rider. Exhibitors in this class must show in Western clothing and tack. For safety reasons, proper tack, fitting the rider, must be required.
- 137. Pee Wee Walk-Trot Western Pleasure A horse or pony is allowed in this class. Points in this class are awarded to the horse/pony. Exhibitors in this class must show in Western clothing and tack.** For safety reasons, proper tack, fitting the rider, must be required.
- 138.** Pee Wee Walk-Trot English Equitation: A horse or pony is allowed in this class. Points in this class are awarded to the rider. Exhibitors in this class must **show** in English clothing and tack.
- 139. Pee Wee Walk-Trot English Pleasure: A horse or pony is allowed in this class. Points in this class are awarded to the horse/pony. Exhibitors in this class must show in English clothing and tack. (A figure eight coil or large looping ring is recommended as a safety measure.) Horse should lead readily at a walk and trot. Keep alert and watch for any signal given by Judge or Ringmaster.**
- 140.** Pee Wee Walk-Trot Horse/Pony Performance 10 years and under (pattern required). A horse or pony is allowed in this class. This class is not to be considered a pleasure class. These exhibitors should be able to perform pleurably both ways of the rail and include the walk and trot. They will be asked to execute additional individual work. This class is to be judged 50% rail work and 50% individual work. The judge must post an appropriate pattern by noon break. Points in this class are to be awarded to the horse.

#### **GREEN HORSE OR GREEN RIDER DIVISION**

- 141.** This is a walk/trot class and is open to exhibitors ages 11 & Over or horses and ponies who are considered to be either a "Beginner/Green Rider" or "Green Horse"
- a. The exhibitor/equine combination is prohibited from showing in all other performance classes.
  - b. The equine is prohibited from showing in all other performance classes if it was considered the "Green Horse" for this class.
  - c. The exhibitor is prohibited from showing in all other performances classes if he/she was considered the "Green Rider" for this class.
  - d. English and Western exhibitors may participate, but clothing and tack may not be mixed.
  - e. For safety reasons, proper tack, fitting the rider, must be required.
  - f. Green Horse or Green Rider classes are non-money classes.

#### **PONY DIVISION**

- 142.** This division is open to ponies less than 56 inches or under 14 hands.
- 143.** Ponies are allowed in the following classes only.
- a. Open Pony Halter under 56"
  - b. Open English Halter
  - c. Open Pony Showmanship
  - d. Open Pony Western Horsemanship
  - e. Open Pony Western Pleasure
  - f. Open Pony English Equitation
  - g. Open Pony English Pleasure
  - h. Open Performance (pattern required)
  - i. Open Reining
  - j. Sr. Horse/Pony Pleasure
  - k. Jr. Horse/Pony Pleasure

- I. Open Trail
- m. Open Cloverleaf
- n. Open Down and Back
- o. Open Cross Rail
- p. Open Over Fences

144. Ponies may be shown in Pee Wee & Lead-Line classes as per division rules.

145. Ponies must only be shown in their division classes if offered. Exhibitors cannot show a pony in a class in the pony division and in a similar type class in the horse division. Example: If a pony is shown in pony showmanship, it cannot be shown in any other showmanship class.

**Exception:** If classes are not offered, an exhibitor may take a pony into a similar type class in the horse division. Ponies may go into any OPEN classes offered. Example: Open English Halter, Open Performance, Open Reining, Jr. or Sr. Horse/Pony Pleasure, etc.

146. Point Approved Classes:

- a. Halter, open to ponies under 56" (ALL Ages)
- b. Open Pony Pleasure. This class is considered a Pleasure Class (NO Stallions). This is judged on the pony.
- c. Open Pony Equitation or Horsemanship. This class is judged on the rider.

147. Halter Classes will be judged on Conformation, Finish, Manner and Way of Going.

148. Open Pony Pleasure and Open Pony Equitation/Horsemanship are open to all ponies, registered or non-registered. To be judged on the suitability of pony to rider, conformation, and performance.

149. Open Pony Pleasure and Pony Equitation classes will be judged under Pleasure Horse and Equitation/Horsemanship class rules.

150. Measurement of Ponies

- a. Stand the animal on a smooth, level surface, in such position that the front legs are vertical and the back of the hocks in a vertical line with the point of the pony's quarter. The head is to be held low enough to reveal the highest point of the wither and no lower. With the pony in this position, measure the vertical distance from the highest point of the withers to the ground. The arm of the measuring standard shall be placed over the highest point of the withers and no measurement taken at any part of the pony's body shall count. The standard must be a straight, stiff, unbendable stick, and should be provided with a plumb bob or spirited level to make sure the standard is perpendicular from the withers to the ground, and that the cross piece is parallel with the ground surface. Two or more Officials for accuracy must check All measurement devices.
- b. In classes restricted to ponies, no questionable animal may be shown unless the owner possesses a measurement card issued by MAWHC. Every questionable MAWHC pony must be measured each year until it reaches the age of 6, at which time it will be issued a measurement card which is good for life of the pony. Questionable to mean between 53" and 56".
- c. The measurement must take place at a recognized show in which the pony competes. The pony must be measured individually by three Board of Directors. It shall be designated whether the pony is shod or is barefoot. 3/8" shall be allowed for shoes.
- d. The height of any pony may be questioned by an Exhibitor or Show Official without a protest to determine whether or not the pony is being shown the way it was originally measured, and that the owner is in possession of a valid measurement card (The card to be signed by those who measured the pony.)

#### **OVER 30 CLASS**

151. This class is open to all exhibitors 30 years of age or older. It is judged 50% on the rider and 50% on the horse's way of movement. Points are not counted towards High Point Awards only individual class and Special Year End awards.

- a. English and Western exhibitors may participate, but clothing and tack may not be mixed.

### **JUNIOR HORSE/PONY PLEASURE CLASS**

- 152.** Only horses/ponies five years and younger can be shown in the Junior Horse/Pony Class.
- a. Five years and younger can shown in with a Bosal or snaffle bit.
  - b. English or Western Exhibitors may participate, but clothing and tack may not be mixed.

### **SENIOR HORSE/PONY PLEASURE CLASS**

- 153.** Only horses/ponies six years and older can be shown in the Senior Horse/Pony Class.
- a. Six years and older must be shown in curb bits only.
  - b. English or Western Exhibitors may participate, but clothing and tack may not be mixed.

### **OPEN PERFORMANCE CLASS**

- 154.** This class is not to be considered a Pleasure Class. These Exhibitors should be able to perform pleausrably both ways of the rail and include; the walk, trot, and lope. They will be asked to execute additional individual work. Hand gallop (extended lope) is not allowed in this class, except for individual work-offs. This class is to be judged 50% Rail Work and 50% Individual Work-Offs. Rail work at the judge's discretion will be optional.
- a. English or Western Exhibitors may participate, but clothing and tack may not be mixed.
- 155.** When asked to execute individual work the three types of movements should be picked from the list below, and incorporated into a pattern, which will be posted at the entry booth.
- a. Figure eight; simple lead change.
  - b. Lope a left lead. Stop, lope a right lead.
  - c. Pivot right or left, no more than 90 degrees.
  - d. 360 spin.
  - e. Right roll back or left roll back.
  - f. Figure eight, with flying lead change.
  - g. Ride two circles. First circle small and slow, second circle larger and faster.
  - h. Run with speed past marker. Stop and Back up to the center.
  - i. Sliding stop.
  - j. Back.
  - k. Hand gallop.

### **156. OPEN REINING CLASS**

- a. In an approved reining class, anyone of the 3 approved reining patterns may be used. One of these 3 patterns is to be selected by the Judge of the class and used by all contestants in the class.
  - b. The reining pattern will be posted at the entry booth at noon break.
  - c. Each contestant will perform the required pattern individually and separately. Horse shall rein and handle easily, fluently, effortlessly, and with reasonable speed throughout the pattern. Any horse not following exact pattern will be disqualified.
  - d. Scoring will be 0 to 100 with 70 being an average score. Each horse will be judged on neatness, dispatch, ease, calmness, and speed with which the pattern is performed.
  - e. A Judge may require any Contestant to repeat his/her performance of any or all of the various parts of the pattern.
  - f. Faults against the horse (to be scored accordingly, but not to cause disqualification):
  - g. Opening mouth excessively (when wearing bit).
  - h. Excessive jawing opens mouth, or head raising on stop.
  - i. Breaking gaits.
  - j. Lack of smooth, straight, stop on haunches (bouncing or side-ways stop.)
  - k. Refusing to change leads.
  - l. Anticipating signals.
  - m. Stumbling or falling.
  - n. Wringing tail.
  - o. Backing sideways.
  - p. Knocking over markers.
- 157.** Faults against the rider (to be scored accordingly, but not to cause disqualification):
- a. Changing hands on reins.
  - b. Two hands on reins (except in straight Hackamore classes).
  - c. Losing stirrup or holding on.

- d.** Any unnecessary aid given by the rider (such as unnecessary talking, petting, spurring, quirting, jerking of reins, etc.)
  - e.** In the reining patterns, failure to run figure 8 within the markers and/or rollbacks beyond the markers is to be considered a fault and not a disqualification.
  
- 158.** Only one hand may be used on reins and hands must not be changed except for straight Hackamore classes or junior horses in snaffle bits or bosal. Hand to be around reins. One finger between reins permitted.
  - a.** While horse is in motion, rider's hands shall be clear of saddle.
  - b.** Spurs or romal shall not be used forward of the cinch.
  
- 159.** Reining equipment:
  - a.** If a bit is used, it shall be a grazing, snaffle, curb, half-breed, bar, or spade bit.
  - b.** Chain curbs are permissible, but must meet the approval of the judge, must be at least one-half inch in width, and lie flat against the jaw of the horse.
  - c.** No wire curbs, regardless of how padded or covered; no chinstrap narrower than one-half inch; no nose band; nor tie downs will be permitted.

## REINING PATTERN A

Mandatory marker along fence or wall.

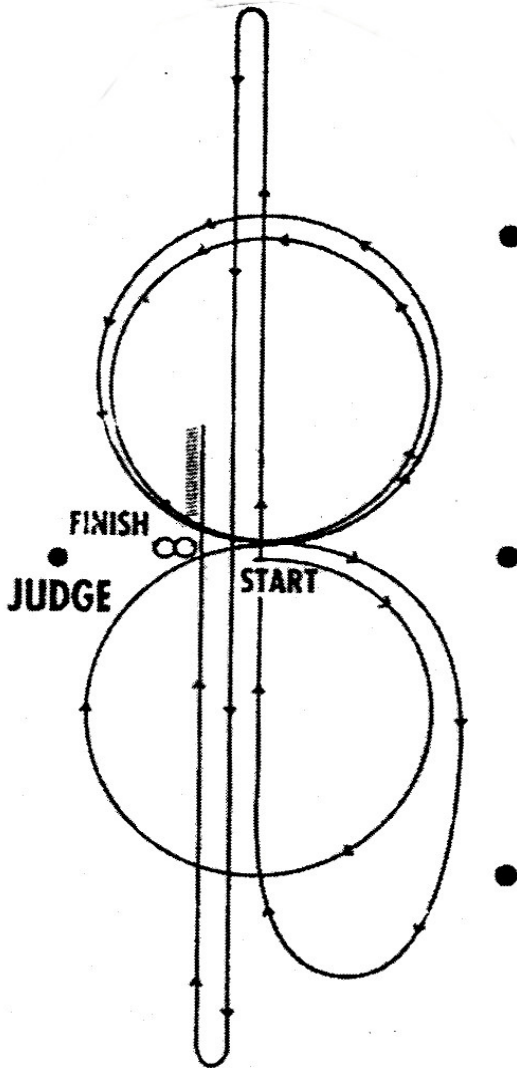

Ride Pattern as follows:

1. Beginning at the center, facing right wall or fence, take a right lead and do a circle to the right, away from the judge, of moderate size and speed.
2. At the center of the arena, change leads and do two circles to the left both of moderate size and speed.
3. At the center of the arena change leads.
4. Go to the end of the arena without stopping or breaking gait, and begin run down near the approximate center of the arena run the length of the arena past marker.
5. Do a square, sliding stop, then hesitate.
6. Turn left and begin a run to the opposite end of the arena: run length of arena past marker.
7. Do a square, sliding stop, then hesitate.
8. Turn right, and begin a run down past the center marker of the arena.
9. Do a sliding stop, and back to the center of the arena or at least 10 feet. Let the horse settle in approximate area of the stop.
10. Do a 360-degree spin to the right.
11. Do a 360-degree spin to the left.
12. Hesitate to show completion of pattern.  
Approach judge for inspection and dismissal.

## REINING PATTERN B

Mandatory marker along fence or wall

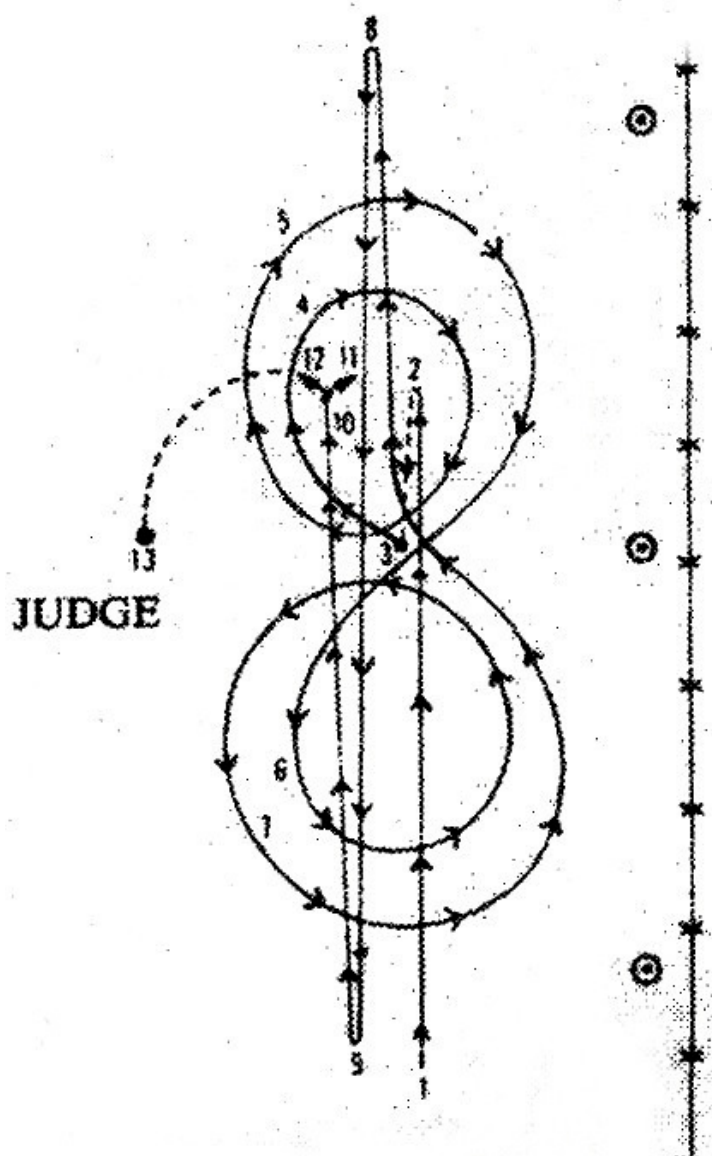

1. Run with speed, past center marker.
2. Stop and back up to center of pattern.
3. Settle horse for approximately 10 seconds. Start lope.  
Circles should be made inside the end markers.
4. & 5. Ride two circles to the right; first circle small, and slow, and second circle larger and faster.
6. & 7. Ride two circles to the left, first circle small, and slow, second circle larger and faster.
8. Left roll back over hocks (should be made past far end marker).
9. Right roll back over hocks (should be made past far end marker).
10. Stop (should be made past center marker). Let horse settle, then in approximately area of stop, do the pivots.
11. Pivot right or left no more than 90 degrees.
12. Pivot opposite direction, no more than 180 degrees.
13. Walk to judge and stop for inspection until dismissed.

## REINING PATTERN C

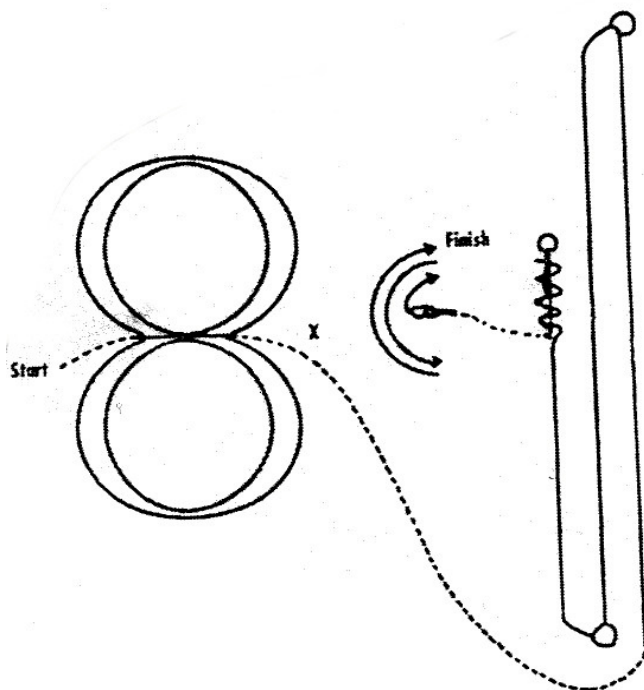

Ride pattern as follows:

1. Begin works to the right.
2. First figure eight
3. Second figure eight. Then after final lead change (before point X) proceed to point 4 at a walk.
4. Begin run.
5. Sliding stop.
6. Turn left away from rail and begin second run.
7. Sliding stop.
8. Turn right away from rail and do short run.
9. Sliding stop.
10. Back up.
11. Quarter turn to right or left.
12. Half turn to opposite direction.
13. Half turn to direction taken in # 11.
14. Walk to judge unless dismissed.



**RULES GOVERNING ALL CONTEST EVENTS**  
**GENERAL RULES**

- 161.** Two hands may be used at any time while horse is in motion for riding, balancing and stopping; if any rider pull- reins, jerks, whips his horse with the reins, or bleeds his, horse's mouth while showing, he will be dismissed from class. Bats and spurs will be allowed, but must be used back of the cinch. However, in-humane use of bats or spurs will disqualify a rider.
- 162.** A bat is defined as follows:
- a. Two strips at least 1 1/2 inches wide stitched together approximately 3/4 of the way up each side and across the top to leave the remaining strips open. Some bats may have a thin metal strip stitched between the two strips for support. The metal strip **MUST** be completely concealed. Picture in book
  - b. Leather or plastic-wrapped fiberglass shaft no longer than 2 1/2 feet. A leather popper no less than 1 1/2 inches wide must be on the end. Picture in book. At no time will the Association accept sticks, hoses, straps, or any other substitute, not in accordance with the specific rules above.
- 163.** In contesting, curb chains and tie downs are permitted.
- 164.** A re-ride shall not be permitted for breaking of equipment in a timed event.
- 165.** In all timed events, time shall start when horse's nose crosses starting line and shall stop when horse's nose crosses the finish line. Electric timers may be used or two stopwatches with the average time of the watches used by the Official Timers to be the official time. When electric timer is used stopwatch must also be used in case of failure of electric timer. When electric timer is used, the time will not start until the horse or pony's nose crosses the line between the two kegs that designates the starting line. If the horse or pony goes on and completes the pattern before going through the starting line, he will be disqualified.
- 166.** No Official may time a member of his family, and the Official Timer may not show in contest classes. The Official Timer must read the electric timer.
- 167.** Number 8 penny nail kegs or any other suitable equipment of approximate size (not over 14" in diameter or 18" in height) to be used in Bending, Speed and Action contests, and Flag Races.
- 168.** The contestants can make the choice of equipment in contests as long as it is humane and in accordance (with the rules governing such contests).
- 169.** Personal Attire: In all contest events the following must be worn: Western boots and western type pants, collar-type blouse or shirts (no t-shirts, sweatshirts or tank-type shirts or blouses). Western hats, hard hat or protective leg gear are optional. Chaps and spurs are optional. If western hats or hard hats are not worn, no other hat may be worn.
- 170. Two (2) or more different people may show no horse in the same contesting event.**
- 171.** Waiting horses may group in one corner of the arena by Judge.
- 172.** In all contest events horses must start and stop inside the arena, otherwise horses will be disqualified. The Judge must indicate when the horse may start and when gate shall be opened to let horse out. Exception: Speed and Action, when horse must stop within designated rectangle.
- 173.** Horses will be disqualified for breaking pattern of event. If a horse or pony tips over a key or a barrel, passes barrel or key and has to back or turn back to pick it up or turns the wrong direction, such as a roll back, he will be considered breaking the pattern. Unless all four feet of a horse or pony gets around the keg he will be disqualified for jumping.

174. In case of ties in timed events the following rules apply. Any two or more Contestants whose time is tied for first place will be required to make one re-run and the best time will win first place, the next best second place, etc. Ties must be run off within one second of original time. If the first Contestant disqualifies and the second qualifies, then the first Contestant would receive second place and the other Contestant would receive first place, etc. In case they tie again, they must flip for their placing. The above rules apply to any other ties for the rest of the placing. If not six qualifiers they must have one re-run, then if not enough qualify they must flip for placing.
175. In the event a class is offered at an approved show the conditions of which conflict with the rules of the Association, said rules shall prevail and govern the acts of management and judges. Class specifications in prize lists of approved shows shall not contradict the Association rules.
176. Rules number 18 and 68 will also apply in contesting.
177. 2 kegs or markers shall designate starting line in contest events. If, because of limited space, the distance in any contest is less than specified, it must be announced.
178. An exhibitor is responsible for his or her eligibility in any class and is subject to forfeiture of entry fee, prizes, points, and will be suspended for 39 days from approved shows from the day of violation upon improper entry. An exhibitor or contestant must show in the proper age classification. Show Committee may request proof of age.
179. **AGE GROUP FOR CONTEST EVENTS**
180. Children shall be those Contestants under 18 years of age.
181. Adults shall be those Contestants 19 years of age and over.
182. For horse show purposes the age of an Exhibitor or Contestant on January 1st of that show year, shall be considered his age for that entire show season.
183. **The Judge shall have the right to eliminate any horse from show ring whose manner is deemed unsafe to other horses or riders. The Judges decision shall be final in all cases. The Ring Committee shall maintain the right to refuse to any Exhibitor the privilege of showing in any event should his or her conduct be deemed unsuitable to the dignity of the show; or should his or her horse be considered dangerous to the welfare of any or all people. These classes open to Stallions, Mares, and Gelding. (Unless otherwise specified).**

## CLOVER LEAF PATTERN

184. Two kegs set 16 feet apart will be the starting line. Three (3) 55 gallon barrels to be used to form the pattern. One barrel to be 100 feet to the right, another barrel 100 feet to the left of the center of the starting line at about a 60 degree angle; another barrel set in center of arena 200 feet from the starting line will complete the pattern. If the course is too large for the available space, the pattern should be reduced five (5) yards at a time until the pattern fits the arena. Brightly colored 55-gallon drums with both ends in should be used. When measuring the arena for the course, remember to leave ample room for horses to complete their turns and stop at the finish. Starting line markers shall be place 16 feet apart in the middle of the arena on the starting line. Electric timer or at least two (2) watches shall be used, with the time indicated by the electric timer or average time of the watches used by official timers to be the official time. The contestant is allowed a running start. Timing shall begin as soon as the horse's nose reaches the starting line and will be stopped when the horse's nose passes over the finish line. At the signal from the starter, the contestant will run to barrel number 1. Pass to the left of it and complete an approximately 360-degree turn around it; then go to barrel number 2. Pass to the right of it, and complete a slightly more than 360 degree turn around it; then go to barrel number 3. Pass to the right of it and do another approximately 360-degree turn around it; then sprint to the finish line, passing between barrels number 1 and 2, also passing between starting line markers. This pattern may also be run to the left. Knocking over a barrel shall carry a five (5) second penalty. Horse will be disqualified if a barrel is tipped over, touched with the hand, if pattern is broken, or if horse fails to start and stop inside the arena. Adult's and Children's Classes shall not be combined in a State Approve.

### Clover Leaf Pattern

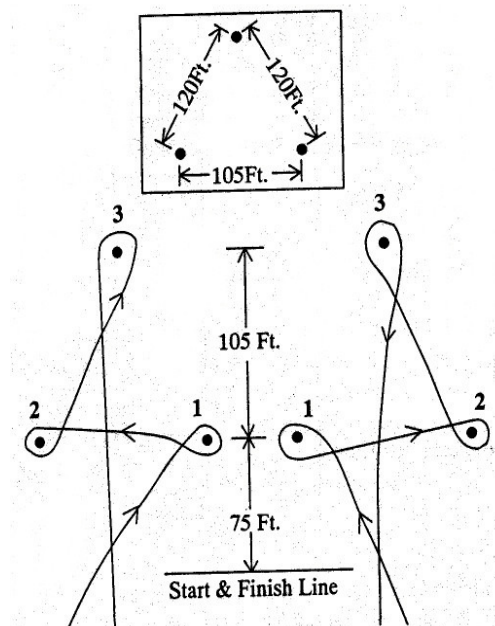

## DOWN & BACK

185. Horse may start and stop inside the arena; other-wise horse will be disqualified. Starting line shall be two kegs set 16 feet apart. Time starts when horse's nose crosses starting line. One 55 gallon barrel to be used to form the pattern. From the starting line contestant must ride 200 feet to barrel, go around barrel and return to finish line. Time stops when horse's nose crosses the finish line. Points, which are award to the rider, will be counted in this division only.

### Down And Back Pattern

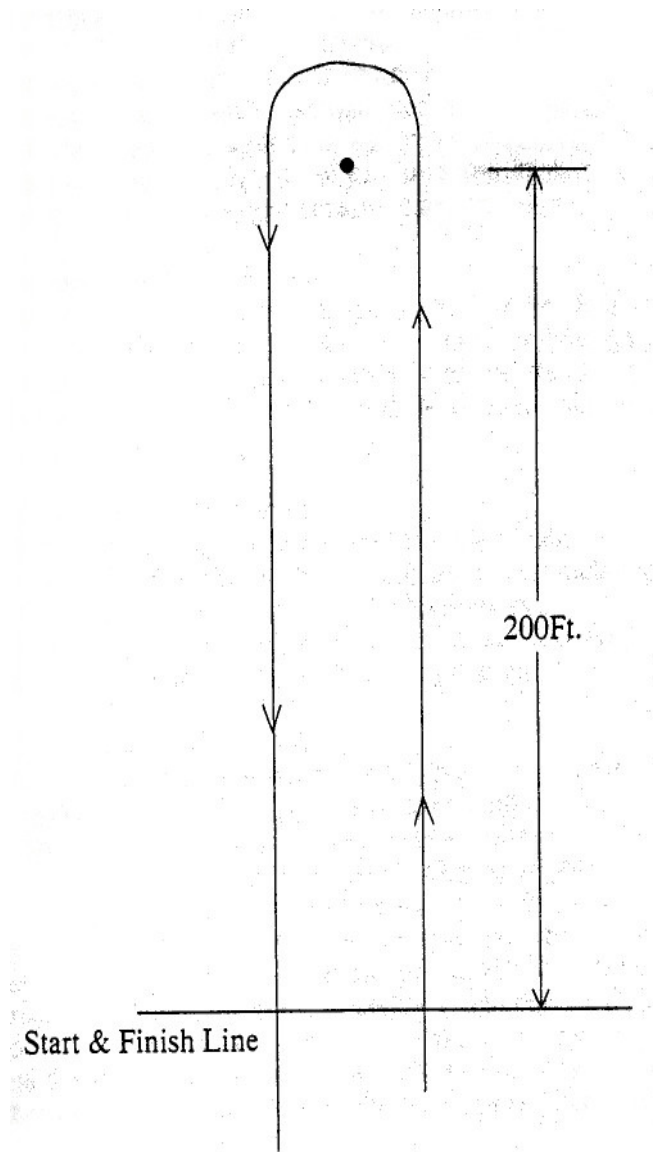

## **OPEN TRAIL CLASS**

**186.** This class is judged on performance of the horse over obstacles. Emphasis is strongly put on manners and proper movement at a walk, trot and canter. Horses to be penalized for speed and unnecessary delays. The walk, trot, and canter are as important as the obstacles. Scoring maybe 1/2 to 1 1/2 plus or minus. The basic score is to be from 1 to 100 with 70 being an average score. The judge's discretion of penalty points will be used at the obstacles.

### **MANDATORY OBSTACLES**

- a.** Four logs, placed for walk or trot over, spaced to suit stride.
- b.** Carry object, possible replacement, and dog leg with a side pass.
- c.** Back through serpentine, pylons or sake barrels no holes on top.

All obstacles will be of safe nature, and may be approved or denied by the MAWHC board of directors. The list of optional obstacles is open to the shows committees. Safe obstacles are to be stressed. No live animals are to be used. Horse must be penalized for delays, and artificial attitude, high heads as not watching footing.

## **MAWHC QUEEN CONTEST:**

**187.** The MAWHC Queen contest will be held after the midway point of the show season. The date and contest criteria will be determined yearly by the Queen Contest Committee and approved by the Board of Directors. Obligations of the Queen are determined by the Board of Directors and the Queen's Committee. Age is determined as of January 1<sup>st</sup> of current show year.

- A.** To qualify as a contestant you must:
  1. Be a MAWHC member in good standing
  2. Be within 14-21 years of age
  3. Have participated in a minimum of five (5) MAWHC shows, prior to the contest, during the current show season
  
- B.** Winning will be based on the exhibitor not the horse. Contest points will be counted at the show and the winner will be announced.
  1. The following classes may be used for the contest
    - a. Showmanship
    - b. English Equitation
    - c. Western Horsemanship
    - d. Oral Interview
    - e. Essay

## **MAWHC YEAR END AWARDS**

### **All Around Champion Horse:**

A year-end award will be awarded to the horse, regardless of the exhibitor, accumulating the greatest number of points in the mandatory classes only. Horses eligible must show in all five qualifying classes 50% of the time offered. *(i.e. if there are 12 total shows for the season, you must show 6 times in each class)* There will be no fee for nomination, however individuals wishing to have their points counted for the All Around horse must collect and submit \$100 in sponsorship by the mid-season show when the mid-season points are published. The exhibitor will fill out and sign the All Around Champion Horse Form stating they understand the requirements for this class and this form must be turned in to MAWHC by the mid-season show date. MAWHC will also award a Reserve All Around Champion Horse. MAWHC will award a saddle to the All Around Champion Horse. *(Minimum of 3 participants or \$300.00 must be submitted by mid-season for a saddle to be awarded.)* The Awards/Banquet Committee will determine the type of saddle awarded yearly and will also determine the Reserve All Around Champion Horse Award.

#### **a. Qualification Classes for All Around points are:**

1. mandatory Sex Halter class
2. mandatory Age English Pleasure class
3. mandatory Age Western Pleasure class
4. mandatory Junior or Senior horse/pony Pleasure class
5. mandatory Open Performance class

- b. If reining or contesting classes are offered at 50% of the shows, and exhibitor shows in them 50% of the time offered, the class will count toward All Around Champion Horse.

### **All Around Champion Pony:**

A Year Award will be awarded to the pony, regardless of the exhibitor, accumulating the greatest number of points in the mandatory classes. All pony classes will count; no PeeWee classes or Lead Line classes will count for this award. Ponies eligible must show in all five qualifying classes 50% of the time offered. *(i.e. if there are 12 total shows for the season, you must show 6 times in each class)* There will be no fee for nomination, however individuals wishing to have their points counted for the All Around Pony must collect and submit \$50 in sponsorship by the mid-season show when the mid-season points are published. The exhibitor will fill out and sign the All Around Champion Pony Form stating they understand the requirements for this class and this form must be turned in to MAWHC by the mid-season show date. MAWHC will also award a Reserve All Around Champion Pony. The Awards/Banquet Committee will determine the awards to be awarded to the Champion and Reserve Champion All Around Pony.

#### **a. Qualification Classes for All Around points are:**

1. mandatory Pony Halter class
2. mandatory Pony English Pleasure class
3. mandatory Pony Western Pleasure class
4. mandatory Junior or Senior horse/pony Pleasure class
5. mandatory Open Performance class

- b. If reining or contesting classes are offered at 50% of the shows, and exhibitor shows in them 50% of the time offered, the class will count toward All Around Champion Horse.

### **High Point Exhibitors:**

Grand & Reserve Champion in these divisions: Pony, Pee Wee 10 & Under, 13 & Under, 14-18, 19 & Over. Will be awarded to the top two exhibitors accumulating the greatest number of points in their age division classes only. All horses shown by the exhibitors will count towards their division. Exhibitors must meet requirements for receiving a year end award to qualify for this award.

**High Point Halter:**

A Year End award will be awarded to the horse accumulating the greatest number of points in one (1) sex halter class, one (1) breed halter class and one (1) optional halter class. All halter points earned, regardless of the number of times shown or the exhibitor, will count towards this award. *(If a horse earns points in two or more optional classes, i.e. English halter, Color halter, 2 & 3 Year Old halter, the class with the highest points earned will be used.)*

**High Point Pleasure:**

A Year End award will be awarded to the horse accumulating the greatest number of points in one (1) age english pleasure class, one (1) age western pleasure class, one (1) breed pleasure class and one (1) Jr. or Sr. Horse/Pony Pleasure Class. All pleasure points earned, regardless of the number of times shown or the exhibitor, will count towards this award.

**Adult Sportsmanship Award:**

Joseph Plott Family Adult Sportsmanship Award, this award is voted on by all MAWHC Adult Members and is given at the awards banquet/dinner. This is a traveling trophy sponsored by the family of Joseph Plott.

**Youth Sportsmanship Award:**

This award is given to the youth member, 18 years or younger, that shows true sportsmanship throughout the show season. This youth member is selected by the officers and Board of Directors. This is a traveling trophy.

**Youth Friendship Award:**

The Tammy Dohm Friendship award is voted on by all MAWHC Youth Members and is given at the awards banquet/dinner. This is a traveling trophy sponsored by the family of Tammy Dohm.

**Grooms Award:**

The Groom's award is selected by and passed on by the previous recipient. This is a traveling trophy.

**Shinville Award:**

The highest ranking award given by MAWHC. This is a life- time membership and achievement award given to outstanding members for their dedication and support of the organization over the years.

## **SPECIAL AWARDS**

**High Point Forty & Over Award:**

The George and Thelma Tutton Memorial Forty and Over Award will be awarded to one forty and over adult with the most accumulated points in all classes. Horses Only. This is a traveling trophy sponsored by the Tutton family.

**High Point Adult Showman Award:**

The Clifford B. & Margaret I. Underwood Memorial High Point Adult Showman Award will be awarded to the one horse/rider combination, 19 years & older, accumulating the most points in Showmanship, Horsemanship and Equitation classes. This is a traveling trophy sponsored by the family of Clifford B. & Margaret I. Underwood.

**Jack Peapples Memorial Youth Award:**

The Jack Peapples Memorial Youth Award is awarded to the one horse/one rider combination, youth 18 years and under, accumulating the greatest number of points in all classes. Horses only are eligible for this award. This is a traveling trophy sponsored by the family of Jack Peapples.

**All Around Youth Showman:**

A year end award will be awarded to the combination of one horse/pony and one rider, 18 years or younger, accumulating the greatest number of points in all Showmanship, Horsemanship and Equitation classes. This is a traveling trophy sponsored by Das Bauerhaus.

**All Around Appaloosa Horse:**

The James L. Hollis Sr. Memorial Award will be awarded to the Appaloosa horse, regardless of exhibitor, with the greatest number of points in all classes. Pee Wee exhibitors are not eligible for this award. This is a traveling trophy sponsored by the family of James L. Hollis Sr.

**All Around Arabian/Half Arab Freedom Trophy:**

Points derived from all classes entered by one Arabian/ Half Arab horse accumulating the highest number of points in all classes entered except for Pee Wee and Lead-line shall be considered the highpoint. This is a traveling trophy.

**All Around Fine Horse:**

Sponsored by the Tutton Family. This is a traveling trophy to be awarded to the eligible Fine Horse accumulating the highest number of points in all classes. Pee Wee and Lead-line points will not be counted for this award.

**All Around Non-Registered Horse/Pony:**

The Virginia Hudak Memorial Trophy will be awarded to the one non-registered horse or pony / one rider combination accumulating the greatest number of points in all classes. Non-Registered Horse Halter or Open Pony Halter is the only halter class that will count towards this award. Pee Wee Exhibitors are not eligible for this award. Sponsored by the Gear Family. This is a traveling trophy.

**All Around Paint Horse:**

Points derived from all classes entered by one registered Paint horse and one rider. The Paint horse/rider combination accumulating the highest number of points in all classes entered shall be considered the highpoint. Pee Wee exhibitors are not eligible for this award. This is a traveling trophy.

**All Around Quarter Horse:**

The Ruby and Leo Daniel McQueen Memorial All Around Quarter Horse Award will be awarded to the registered Quarter horse, regardless of rider, accumulating the greatest number of points in all classes. This is a traveling trophy sponsored by the Tutton family.

**Hi Point English Horse:**

The Midnight Katonic Memorial Award, will be awarded to the, one horse/one rider combination, accumulating the greatest amount of points earned in Open English Halter, (1) age group English Equitation class, and (1) age group English Pleasure. \*Pony or Pee Wee classes will not count toward this award. This is a traveling trophy sponsored by the Rutter family.

**Hi Point Junior Horse/Pony:**

The Cassie's Fly Boy Memorial Trophy is awarded to the Junior Horse/Pony, equine 2-5 years of age, regardless of exhibitor, accumulating the greatest number of points in all classes. To be eligible horse/pony must show in the Junior Horse/Pony class at least 5 times. PeeWee Points will not count towards this award. This is a traveling trophy sponsored by the Double C Equestrian Center.

**Hi Point Senior Horse/Pony:**

The True Blue Farms Trophy is awarded to the Senior Horse/Pony, equine 6 years and older, regardless of exhibitor, accumulating the greatest number of points in all classes. PeeWee Points will not count towards this award. This is a traveling trophy sponsored by the Hartmann Family.

**Special Awards:**

Any award given other than MAWHC awards, by an individual must be designated by May 1 of that show year, and written out specifying the type, and mailed to the Point Secretary.

**Note:** For all Showmanship, Horsemanship and Equitation classes the year-end award will be awarded to the exhibitor, regardless of the horse shown. These awards are given to the person, not the horse. In all other classes, the awards are based on the number of points the horse has earned, regardless of the exhibitor. Please remember that all horses shown must be nominated with the point secretary and all exhibitors must be current members of MAWHC for points to count towards any year-end award.